

Supplementary Material

Figure S1. OSL Helios reader block diagram.

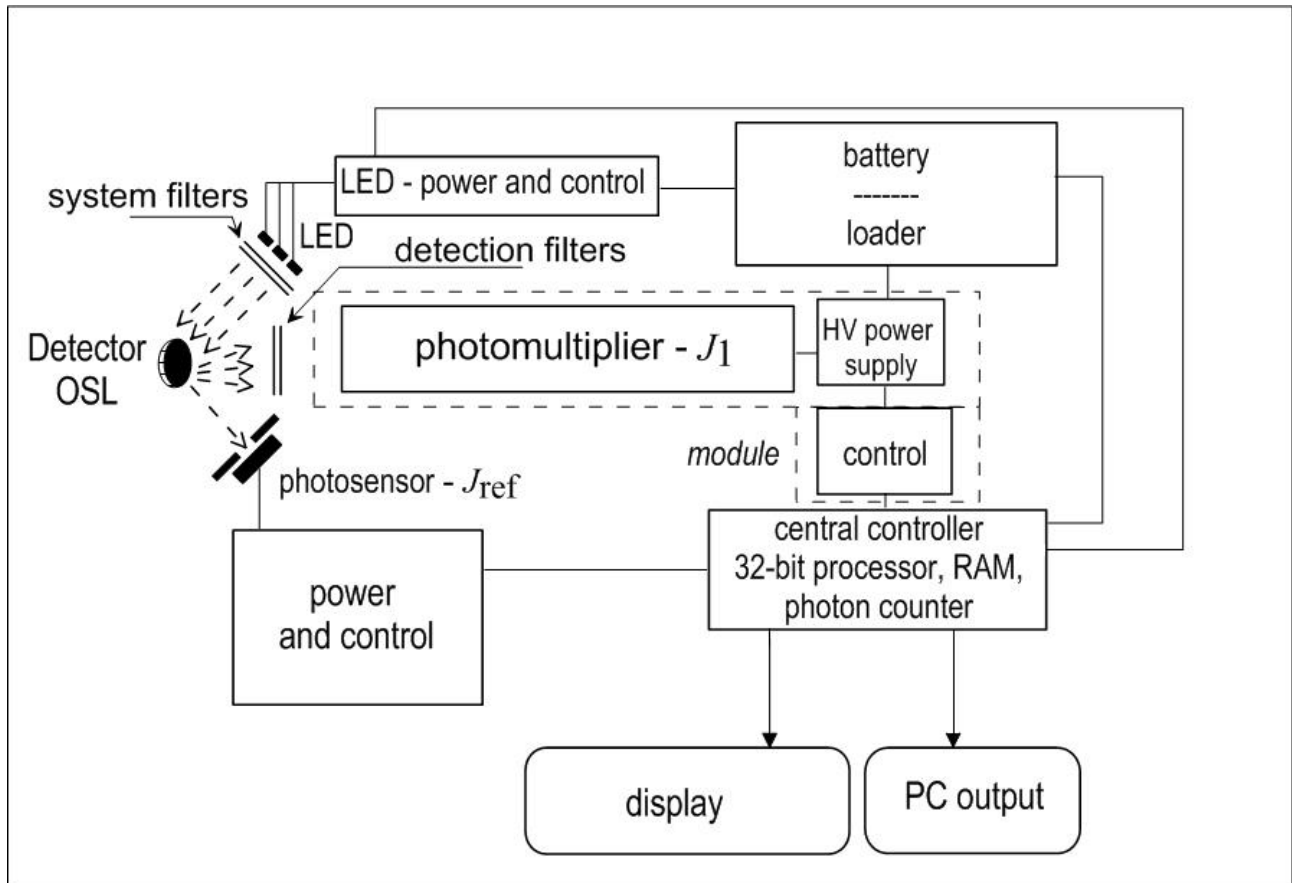
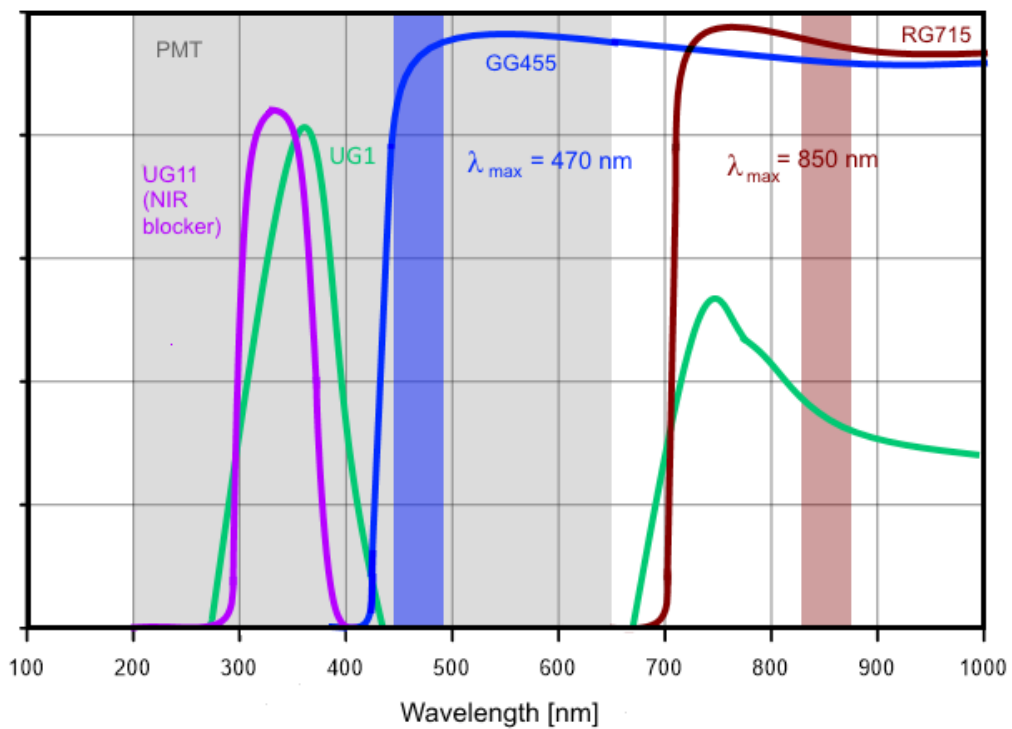

Figure S2. Stimulation and detection range diagram for (a) Helios BL/IR, (b) SUERC.

a)



b)

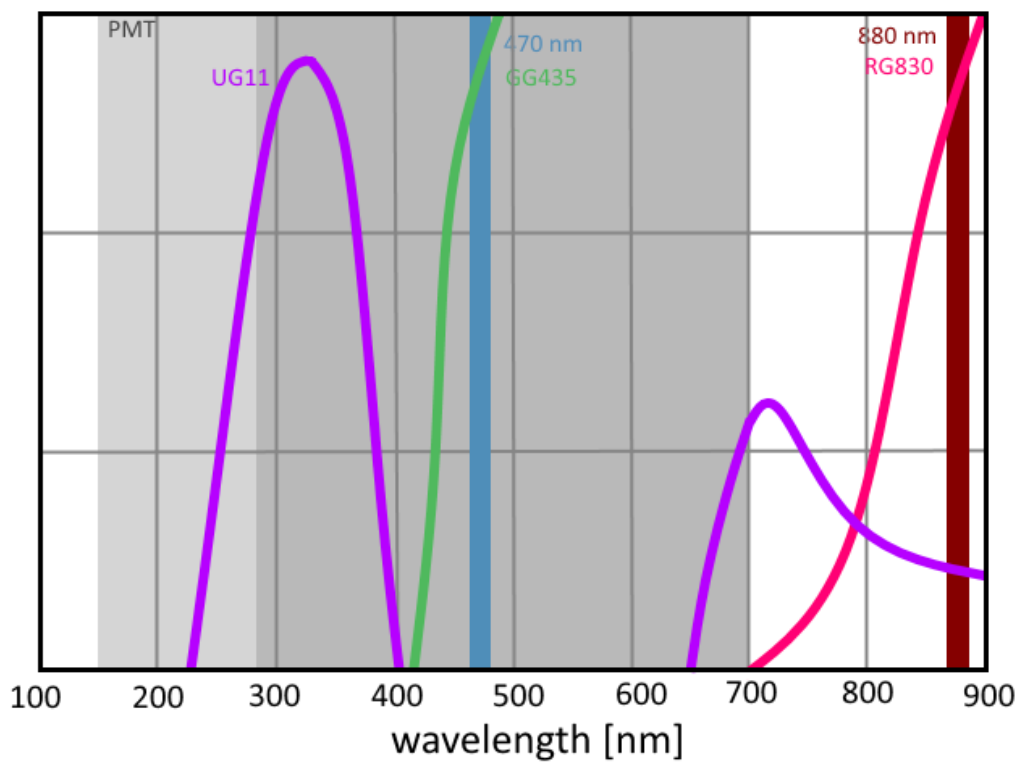

Figure S3. Photos of OSL Helios and SUERC readers with visible sample holders/drawers.



Figure S4. Luminescence profile measured using SUERC and Helios readers: a) IRSL, b) post-IR BSL, c) post-IR GSL. Figure (b) directly compares the Helios and SUERC reader counts (same x-axis scale) under blue stimulation.

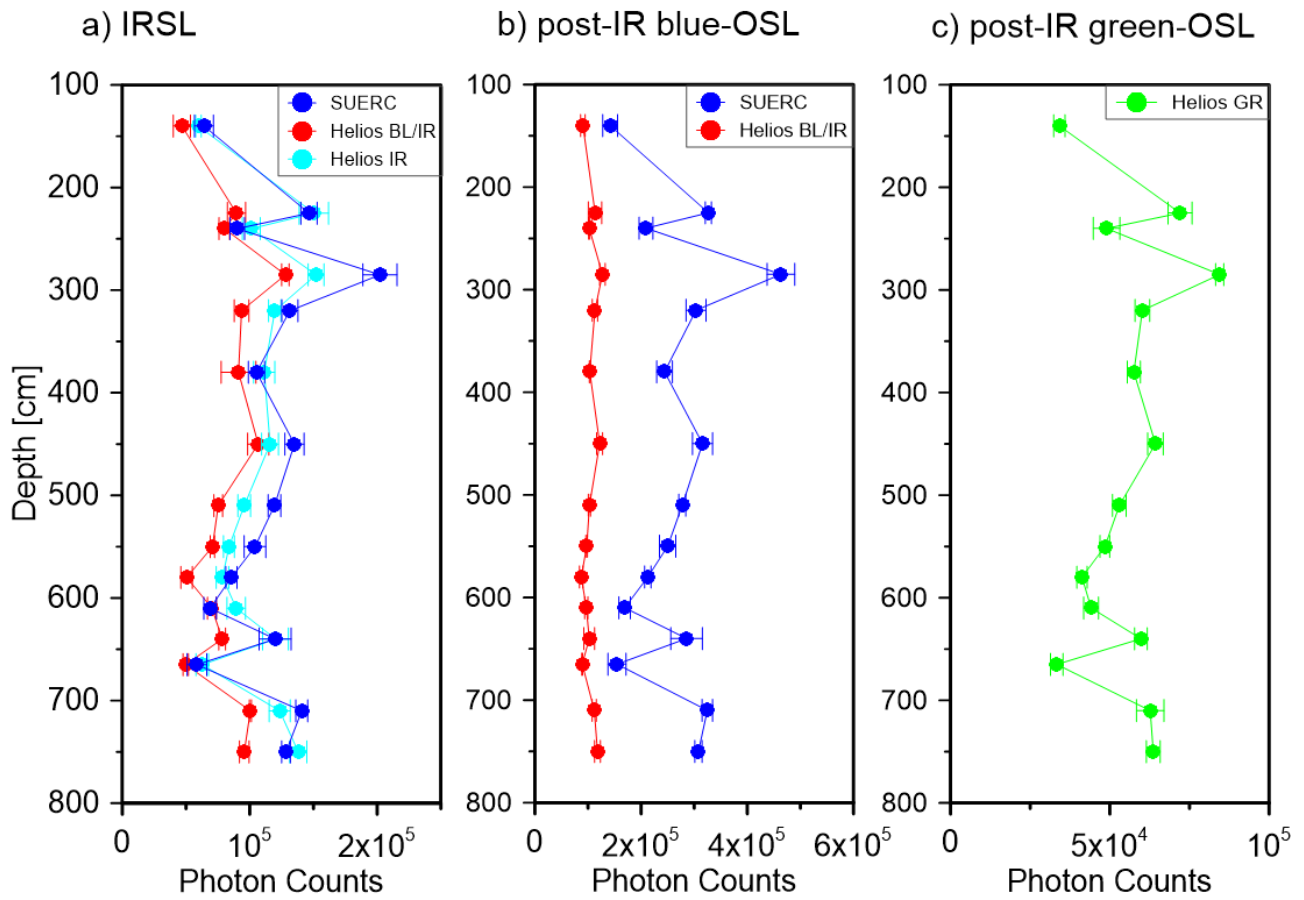

Table S1. Relative standard deviation values calculated from measurements of three subsamples for each sample.

| sample position | SUERC | | Helios BL/IR | | Helios IR | Helios GR |
|-----------------|-------|-------|--------------|-------|-----------|-----------|
| | IRSL | BSL | IRSL | BSL | IRSL | GSL |
| 1 | 20.0% | 17.1% | 25.0% | 4.7% | 6.3% | 9.0% |
| 2 | 7.5% | 3.0% | 13.8% | 11.1% | 13.3% | 9.0% |
| 3 | 10.9% | 10.8% | 9.1% | 1.1% | 12.0% | 14.7% |
| 4 | 11.5% | 9.8% | 3.9% | 4.1% | 7.0% | 2.6% |
| 5 | 8.3% | 10.7% | 10.6% | 4.5% | 7.0% | 6.6% |
| 6 | 10.5% | 10.6% | 24.9% | 0.7% | 13.0% | 6.2% |
| 7 | 9.7% | 10.4% | 13.5% | 4.6% | 9.9% | 6.6% |
| 8 | 7.2% | 4.1% | 7.9% | 2.0% | 9.1% | 7.0% |
| 9 | 14.2% | 10.7% | 4.2% | 1.5% | 8.8% | 5.5% |
| 10 | 8.9% | 4.9% | 15.4% | 3.7% | 11.0% | 6.8% |
| 11 | 12.3% | 11.0% | 8.5% | 3.1% | 14.0% | 9.1% |
| 12 | 18.1% | 18.1% | 5.9% | 9.9% | 14.6% | 5.7% |
| 13 | 22.8% | 18.9% | 7.3% | 1.0% | 13.5% | 10.2% |
| 14 | 5.7% | 5.2% | 1.4% | 3.5% | 11.6% | 11.9% |
| 15 | 4.7% | 3.8% | 6.8% | 4.6% | 8.5% | 5.9% |